

Usage réservé
à 1 utilisateur

NF EN 1263-1

FÉVRIER 2015

www.afnor.org

Ce document est à usage exclusif et non collectif des clients Normes en ligne. Toute mise en réseau, reproduction et rediffusion, sous quelque forme que ce soit, même partielle, sont strictement interdites.

This document is intended for the exclusive and non collective use of AFNOR Webshop (Standards on line) customers. All network exploitation, reproduction and re-dissemination, even partial, whatever the form (hardcopy or other media), is strictly prohibited.



**DOCUMENT PROTÉGÉ
PAR LE DROIT D'AUTEUR**

Droits de reproduction réservés. Sauf prescription différente, aucune partie de cette publication ne peut être reproduite ni utilisée sous quelque forme que ce soit et par aucun procédé, électronique ou mécanique, y compris la photocopie et les microfilms, sans accord formel.

Contacteur :
AFNOR – Norm'Info
11, rue Francis de Pressensé
93571 La Plaine Saint-Denis Cedex
Tél : 01 41 62 76 44
Fax : 01 49 17 92 02
E-mail : norminfo@afnor.org

afnor

BOUTIQUE AFNOR

Nom : HERRY Catherine

Pour : PIRIOU INGENIERIE

Client : 23426798

Commande : N20210601-508351-T

le : 01/06/2021 à 08:58

French standard

NF EN 1263-1

28 February 2015

Classification index: **P 93-311-1**

ICS: 13.100; 13.200; 91.220

Temporary works equipment — Safety nets — Part 1: Safety requirements, test methods

F : Équipements temporaires de chantiers — Filets de sécurité —
Partie 1 : Exigences de sécurité, méthodes d'essai

D : Temporäre Konstruktionen für Bauwerke — Schutznetze (Sicherheitsnetze) —
Teil 1: Sicherheitstechnische Anforderungen, Prüfverfahren

French standard approved

by decision of the Director General of AFNOR.

Replaces the approved standard NF EN 1263-1 of February 2003.

Correspondence

The European standard EN 1263-1:2014 has the status of French standard.

Summary

This document applies to safety nets and their accessories for use in construction and assembly work to protect from deeper fall. It specifies safety requirements and test methods and is based on the performance characteristics of polypropene and polyamide fibres. Materials used in nets should have no significant reduction in mechanical properties between -10 °C and $+40\text{ °C}$.

Descriptors

Technical International Thesaurus: buildings, site equipment, scaffolding, safety nets, work safety, accident prevention, designation, classifications, tensile strength, dimensions, tests, ageing tests: materials, marking, labelling.

Modifications

With respect to the replaced document, revision of the standard.

Corrections

Standards

Standards are designed to serve as a basis in relations between economic, scientific, technical and social partners.

By nature, application of a standard is voluntary. When stipulated in a contract, it is binding on the parties. Legislation may require all or part of a standard to become compulsory.

The standard is a document defined by consensus within a standardisation body involving representatives of all stakeholders. It is submitted for public consultation prior to adoption.

The standard is regularly reviewed to assess its appropriateness over time.

Any standard is considered to be effective as from the date presented on the first page.

Understanding standards

The reader's attention is drawn to the following points:

Only the verbal form **shall** is used to express one or more requirements that shall be satisfied in order to comply with this document. Such requirements may be contained in the body of the standard or in a so-called "normative" annex. For test methods, the use of the imperative corresponds to a requirement.

Expressions involving the verbal form **should** are used to express a possibility that, while preferred, is not actually necessary in order to comply with this document. The verbal form **may** is used to express practical, but not mandatory advice or suggestions, or permission.

Furthermore, this document may provide additional information aimed at making certain elements easier to understand or use, or at clarifying how such elements are applied, but without actually defining a requirement. These elements are presented as **notes or informative annexes**.

Standardisation commission

Acting within a given field of activity, a standardisation commission features the necessary expertise for preparing French standards and defining France's positions in European and international draft standards. The commission may also prepare experimental standards and technical reports.

If you would like to provide feedback on this document, make suggested changes or take part in the document's revision, write to "norminfo@afnor.org".

EUROPEAN STANDARD

EN 1263-1

NORME EUROPÉENNE

EUROPÄISCHE NORM

December 2014

ICS 13.340.60

Supersedes EN 1263-1:2002

English Version

Temporary works equipment - Safety nets - Part 1: Safety requirements, test methods

Équipements temporaires de chantiers - Filets de sécurité -
Partie 1 : Exigences de sécurité, méthodes d'essai

Temporäre Konstruktionen für Bauwerke - Schutznetze
(Sicherheitsnetze) - Teil 1: Sicherheitstechnische
Anforderungen, Prüfverfahren

This European Standard was approved by CEN on 8 November 2014.

CEN members are bound to comply with the CEN/CENELEC Internal Regulations which stipulate the conditions for giving this European Standard the status of a national standard without any alteration. Up-to-date lists and bibliographical references concerning such national standards may be obtained on application to the CEN-CENELEC Management Centre or to any CEN member.

This European Standard exists in three official versions (English, French, German). A version in any other language made by translation under the responsibility of a CEN member into its own language and notified to the CEN-CENELEC Management Centre has the same status as the official versions.

CEN members are the national standards bodies of Austria, Belgium, Bulgaria, Croatia, Cyprus, Czech Republic, Denmark, Estonia, Finland, Former Yugoslav Republic of Macedonia, France, Germany, Greece, Hungary, Iceland, Ireland, Italy, Latvia, Lithuania, Luxembourg, Malta, Netherlands, Norway, Poland, Portugal, Romania, Slovakia, Slovenia, Spain, Sweden, Switzerland, Turkey and United Kingdom.



EUROPEAN COMMITTEE FOR STANDARDIZATION
COMITÉ EUROPÉEN DE NORMALISATION
EUROPÄISCHES KOMITEE FÜR NORMUNG

CEN-CENELEC Management Centre: Avenue Marnix 17, B-1000 Brussels

EN 1263-1:2014 (E)

Contents		Page
Foreword		4
Introduction		5
1 Scope		6
2 Normative references		6
3 Symbols and terms and definitions		6
3.1 Symbols		6
3.2 Terms and definitions		8
4 Classification		9
4.1 Nets		9
4.2 Safety nets		9
4.3 Ropes		12
5 Designation		14
5.1 Safety net		14
5.2 Rope		14
6 Requirements		14
6.1 Construction		14
6.2 Tensile strength of ropes		16
6.3 Energy absorption capacity of the test mesh		16
6.4 Static strength of a net sample		16
6.5 Dynamic strength of safety net System S (net with border rope)		17
6.6 Dynamic strength of safety net System T (net attached on brackets for horizontal use)		17
6.7 Dynamic strength of safety net System U (net attached to supporting construction for vertical use)		17
6.8 Dynamic strength of safety net System V (net with border rope attached to a gallow type support)		17
7 Test methods		17
7.1 General		17
7.2 Dimensional inspection of the mesh size		18
7.3 Test method for mesh rope		19
7.4 Test for the static strength of nets		21
7.5 Test for the breaking load of border-, tie- and coupling ropes		23
7.6 Test for the energy absorption capacity of the net mesh		23
7.7 Natural ageing test		23
7.8 Artificial ageing test		26
7.9 Testing the dynamic strength of safety nets System S (net with border ropes)		31
7.10 Testing the dynamic strength of safety nets System T (nets attached on brackets for horizontal use)		32
7.11 Testing the dynamic strength of safety nets System U (net attached to supporting framework for vertical use)		35
7.12 Testing the dynamic strength of safety nets System V (net with border rope attached to a gallow type support)		36
7.13 Test report		37
8 Marking and labelling		38
9 Handling instructions		38
10 Conformity		38

EN 1263-1:2014 (E)

Annex A (informative) Prototype assessment	39
Annex B (informative) On-going production inspection	40
B.1 On-going production inspection	40
B.2 Annual inspection of test mesh	41
Bibliography	42

EN 1263-1:2014 (E)

Foreword

This document (EN 1263-1:2014) has been prepared by Technical Committee CEN/TC 53 "Temporary works equipment", the secretariat of which is held by DIN.

This European Standard shall be given the status of a national standard, either by publication of an identical text or by endorsement, at the latest by June 2015 and conflicting national standards shall be withdrawn at the latest by June 2015.

Attention is drawn to the possibility that some of the elements of this document may be the subject of patent rights. CEN [and/or CENELEC] shall not be held responsible for identifying any or all such patent rights.

This document supersedes EN 1263-1:2002.

This European Standard is one of a series of standards as listed below:

- EN 1263-1, *Temporary works equipment — Safety nets — Part 1: Safety requirements, test methods*
- EN 1263-2, *Temporary works equipment — Safety nets — Part 2: Safety requirements for the erection of safety nets*

The significant changes incorporated in this revision are:

- a) replacement of Figure 4;
- b) addition of a new rope denominated "W" in Table 2;
- c) deletion of designation for nets;
- d) change of designation for ropes;
- e) complete revision of Clause 7 (test methods), incorporation of the description of a new vertical test rig and new figures for the mash samples;
- f) revision of dimensional inspection of the mesh size;
- g) replacement of Figure 9 and Figure 10 with new figures in 7.7.4.2 (interpretation of the results).

According to the CEN-CENELEC Internal Regulations, the national standards organizations of the following countries are bound to implement this European Standard: Austria, Belgium, Bulgaria, Croatia, Cyprus, Czech Republic, Denmark, Estonia, Finland, Former Yugoslav Republic of Macedonia, France, Germany, Greece, Hungary, Iceland, Ireland, Italy, Latvia, Lithuania, Luxembourg, Malta, Netherlands, Norway, Poland, Portugal, Romania, Slovakia, Slovenia, Spain, Sweden, Switzerland, Turkey and the United Kingdom.

Introduction

Safety nets for use in construction and other assembly work, e.g. as devices to catch falling persons during the construction of halls and bridges, in open line construction as side protection, as anti-fall devices or devices to catch falling persons on working scaffolds, as side protection for safety scaffolds at roofs and in tunnelling can be chosen as a technically suitable and economic solution to catch persons falling from a height. They serve to protect from deeper falls even when large areas in plan occur.

In contrast to being secured by personal protective equipment against falls from heights the mobility of persons working above the area protected by safety nets is not impaired during all work activity. Moreover, the use of safety nets has the advantage to catch persons falling from a height more softly than lanyards caused by large plastic deformations of the net.

Attention should be paid to the fact that the ageing sensitivity of safety nets due to exposure to UV requires that they are exposed to open air condition a limited time only and then be withdrawn from service. For the evaluation of the ageing behaviour tests have been carried out over a period between 6 months and 24 months which apply to the most commonly used materials polyamide and polypropylene. The specifications of the limit values of breaking energy are based on these tests and on drop tests with articulated dummies and test spheres. After having been subjected to respective loading by persons falling from height the safety nets should be replaced, if appropriate.

EN 1263-1:2014 (E)

1 Scope

This European Standard applies to safety nets and their accessories for use in construction and assembly work to protect from deeper fall. It specifies safety requirements and test methods and is based on the performance characteristics of polypropene and polyamide fibres. Materials used in nets should have no significant reduction in mechanical properties between -10 °C and $+40\text{ °C}$.

This European Standard is not applicable to the installation of safety nets. For a European Standard covering the installation of safety nets, see EN 1263-2.

2 Normative references

The following documents, in whole or in part, are normatively referenced in this document and are indispensable for its application. For dated references, only the edition cited applies. For undated references, the latest edition of the referenced document (including any amendments) applies.

EN 1263-2:2014, *Temporary works equipment — Safety nets — Part 2: Safety requirements for the erection of safety nets*

EN ISO 1806, *Fishing nets — Determination of mesh breaking force of netting (ISO 1806)*

EN ISO 2307, *Fibre ropes — Determination of certain physical and mechanical properties (ISO 2307)*

EN ISO 4892-1, *Plastics — Methods of exposure to laboratory light sources — Part 1: General guidance (ISO 4892-1)*

EN ISO 7500-1, *Metallic materials — Verification of static uniaxial testing machines — Part 1: Tension/compression testing machines — Verification and calibration of the force-measuring system (ISO 7500-1)*

ISO 554, *Standard atmospheres for conditioning and/or testing — Specifications*

3 Symbols and terms and definitions

3.1 Symbols

The mainly used symbols are given in Table 1.

EN 1263-1:2014 (E)

Table 1 — Main symbols

Number	Symbol	Denomination	Unit
1	γ_1	general safety factor for production and handling of the material; $\gamma_1 = 1,5$	—
2	γ_2	specific coefficient for the deterioration due to ageing, see 7.7 or 7.8, γ_2 never less than 1 and shows at least 12 months service life	—
3	l_M	mesh size	mm
4	E_A	action value of energy for a net of class A (characteristic value)	kJ
5	E_B	action value of energy for a net of class B (characteristic value)	kJ
6	E_0	value of breaking energy under reference conditions obtained from the recorded data of a net sample in the as new state	kJ
7	E_{12}	calculated value of breaking energy under reference conditions of a net sample after 12 months of ageing	kJ
8	E_6	calculated value of breaking energy as of a net sample after six month of ageing	kJ
9	E_{vi}	from recorded test data calculated value of energy capacity of the mesh sample i subjected to ageing adjacent to the maximum tensile force F_{vi}	J
10	E_{oj}	from recorded test data calculated value of energy capacity of the mesh sample j in the as new state adjacent to the maximum tensile force F_{vj}	J
11	A_{vi}	definite integral in the interval $0 \leq \Delta v \leq \Delta v_{vi}$ obtained from the recorded data of the breaking test with the mesh sample i subjected to ageing, see Figure 12	cm ²
12	A_{oj}	definite integral in the interval $0 \leq \Delta v \leq \Delta v_{oj}$, obtained from the recorded data of the breaking test with the mesh sample j in the as new state, see Figure 13	cm ²
13	F_{vi}	recorded maximum tensile force of the mesh sample i subjected to ageing	N
14	F_{oj}	recorded maximum tensile force of the mesh sample j in the as new state	N
15	Δv_{vi}	extension at maximum tensile force F_{vi} of the mesh sample i ($i = 1, \dots, 10$) subjected to ageing	m
16	Δv_{oj}	extension at maximum tensile force F_{oj} of the mesh sample j ($j = 1, \dots, 10$) in the as new state	m
NOTE "as new state" means: of the same properties as a new one.			

EN 1263-1:2014 (E)

3.2 Terms and definitions

For the purposes of this document, the following terms and definitions apply.

3.2.1

mesh

series of ropes arranged in a basic geometric pattern (either in squares or diamonds) with four knots or connecting points, forming a net

3.2.2

net

connection of meshes

3.2.3

safety net

net supported by a border rope, other supporting elements or a combination of these designed to catch persons falling from a height

3.2.4

mesh size

distance between two knots or connections of mesh rope measured from the centre to the centre of these connections

3.2.5

mesh rope

rope from which the meshes of a net are manufactured

3.2.6

border rope

rope which passes through each mesh at the perimeter of a net and determines the perimetric dimensions of the safety net

3.2.7

tie rope

rope used for securing the border rope to a suitable support

3.2.8

coupling rope

rope that joins two or more safety nets together

3.2.9

test mesh

section of mesh which is attached into the safety net and which can be removed to determine any deterioration due to ageing without impairing the performance of the net

Note 1 to entry: The test mesh should consist of at least three meshes.

3.2.10

supporting framework

structure to which nets are attached and which contributes to the absorption of kinetic energy in case of dynamic actions

3.2.11

class

classification for the net respective to energy absorption capacity and mesh size

3.2.12 system

assembly of safety net components, which forms an equipment to be used in accordance with the instruction manual

4 Classification

4.1 Nets

This standard specifies four classes of net with maximum mesh sizes (l_M , see Figure 6) and nominated values of energy which may act on the net (E_A and E_B) as follows:

- Class A 1: $E_A = 2,3$ kJ; $l_M = 60$ mm
- Class A 2: $E_A = 2,3$ kJ; $l_M = 100$ mm
- Class B 1: $E_B = 4,4$ kJ; $l_M = 60$ mm
- Class B 2: $E_B = 4,4$ kJ; $l_M = 100$ mm

NOTE The above values E_A and E_B represent the characteristic values of energy and do not include the general safety factor γ , and not the specific coefficient γ_2 for the deterioration due to ageing. These coefficients are described in 6.3.

4.2 Safety nets

Four systems of safety net shall be identified:

- 1) System S: Safety net with border rope (for example, see Figure 1), the smallest size shall be at least 35 m². For rectangular safety nets the length of the shortest side shall be at least 5,0 m;

Small safety nets (less than 35 m² and 5,0 m on the shortest side) are not part of this standard and should be determined by national regulations where applicable.

- 2) System T: Safety net attached on brackets for horizontal use (for example, see Figure 2);
- 3) System U: Safety net attached to supporting framework for vertical use (for example, see Figure 3);
- 4) System V: Safety net with border rope attached to a gallow type support (for example, see Figure 4).

EN 1263-1:2014 (E)

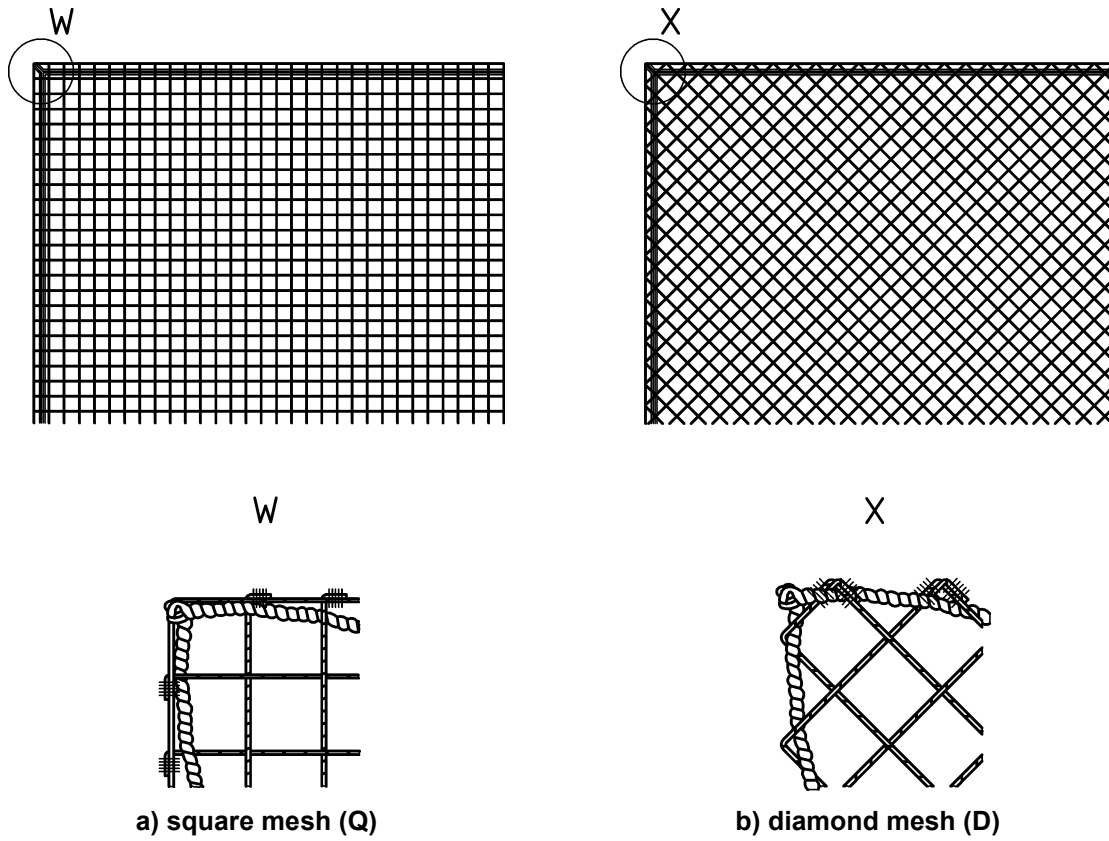

Figure 1 — Safety net System S (net with border rope)

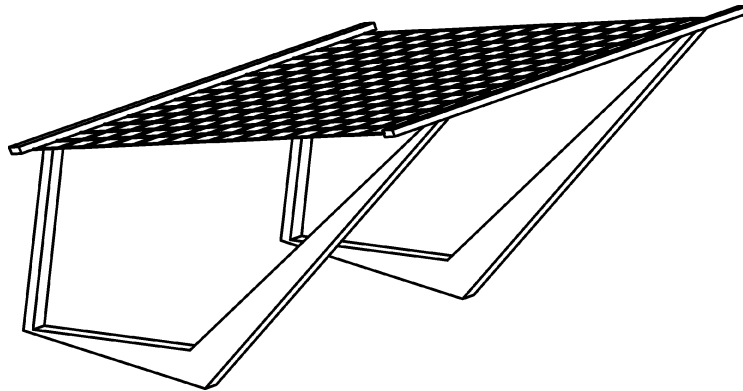

Figure 2 — Safety net System T (net attached on brackets for horizontal use)

EN 1263-1:2014 (E)

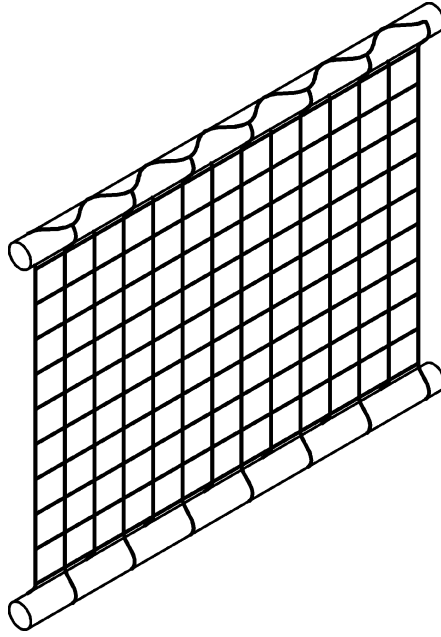

Figure 3 — Safety net system U attached to supporting framework for vertical use

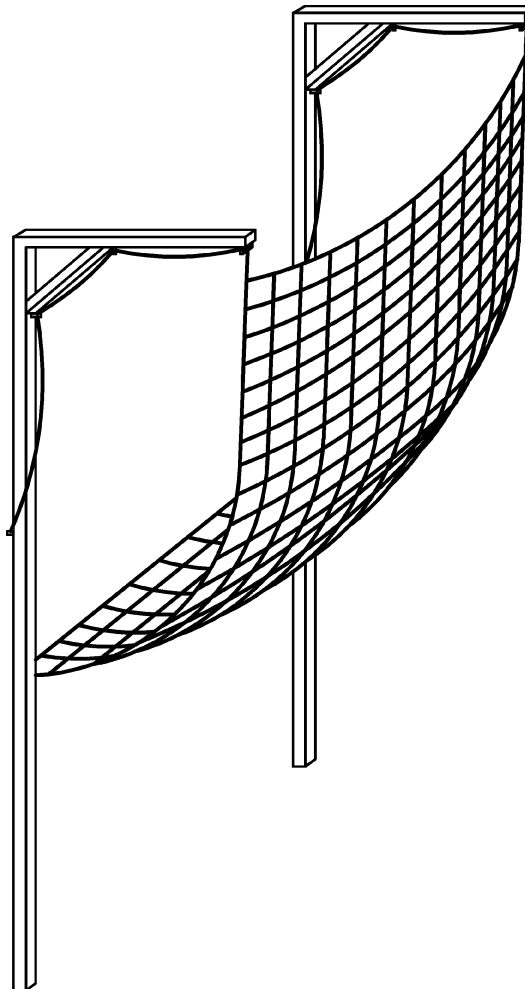

Figure 4 — Safety net System V (net with border rope attached to a gallow type support)

EN 1263-1:2014 (E)

4.3 Ropes

The properties and requirements of ropes that may be used in conjunction with safety nets are given in Table 2. To evaluate those properties, see EN ISO 2307.

Table 2 — Types of ropes, properties and requirements

Denomination	Rope			Minimum tensile strength (kN)					System	Note(s)	Figure 5
	without ends	with a loop	without a loop	7,5	10	15	20	30			
F		x					x ^a		V	Tie rope	b
G			x				x ^a		V	Tie rope	c
H		x			x ^b				V	Tie rope	b
J			x		x ^b				V	Tie rope	c
K	x							x	S	Border rope	a
L		x						x ^a	S	Tie rope	b
M			x					x ^a	S	Tie rope	c
N		x		x					S,T,U,V	Coupling rope	d
O			x	x					S,T,U,V	Coupling rope	e
P	x						x		V	Border rope	a
R		x				x ^b			S	Tie rope	b
W	x						x		T	Border rope	a
Z			x			x ^b			S	Tie rope	c

^a If the net is attached by single ropes.
^b If the net is attached with double ropes.

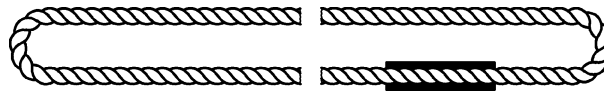

a) Rope K / Rope P / Rope W (border rope)

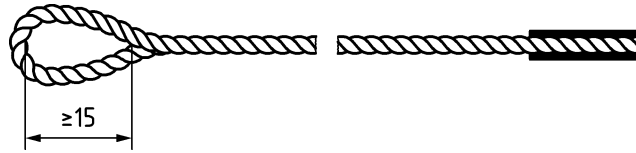

b) Rope L and F (tie rope, single use with only one load bearing diameter)
Rope R and H (tie rope, doubled use with two load bearing diameters)

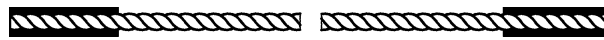

c) Rope M and G (tie rope, single use with only one load bearing diameter)
Rope Z and J (tie rope, doubled use with two load bearing diameters)

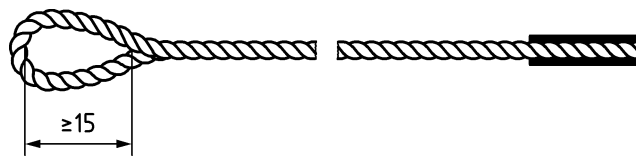

d) Rope N (coupling rope)

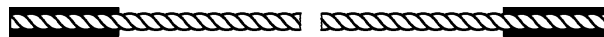

e) Rope O (coupling rope)

NOTE End of ropes are secured to prevent unravelling.

Figure 5 — Ropes

EN 1263-1:2014 (E)

5 Designation

5.1 Safety net

The designation of a safety net shall include its denomination, reference to this European Standard, the system of the safety net, and details of the mesh size, mesh configuration and net size and production inspection level.

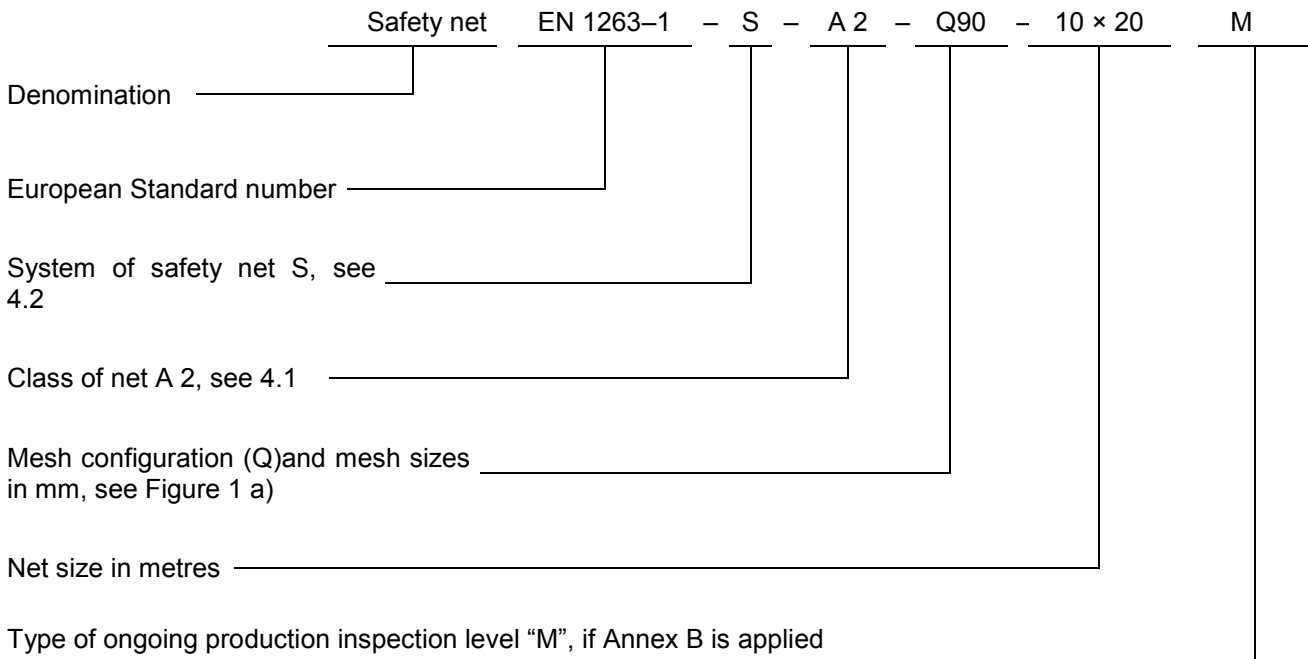

5.2 Rope

The designation of a rope shall include its denomination in accordance with 4.3, Table 2, and a reference to this European Standard.

6 Requirements

6.1 Construction

6.1.1 Mesh rope

The mesh rope construction shall have a minimum of three independent threads and shall be constructed in such a way that it cannot unravel. Mesh rope shall be tested in accordance to 7.3. During the test, the mesh rope shall be able to hold the test mass without sustaining the damage.

NOTE Knotted net construction is unlikely to exhibit this condition.

6.1.2 Net

Nets shall be made with a square (Q) or diamond (D) mesh, see Figure 6 a) and Figure 6 b). The mesh size l_M shall not exceed 60 mm for net classes A 1 and B 1 and 100 mm for net classes A 2 and B 2, see Figure 6.

The mesh size shall be checked in accordance with 7.2.

The loose ends at the edge of the net shall be secured to prevent the net unravelling, see Figure 6.

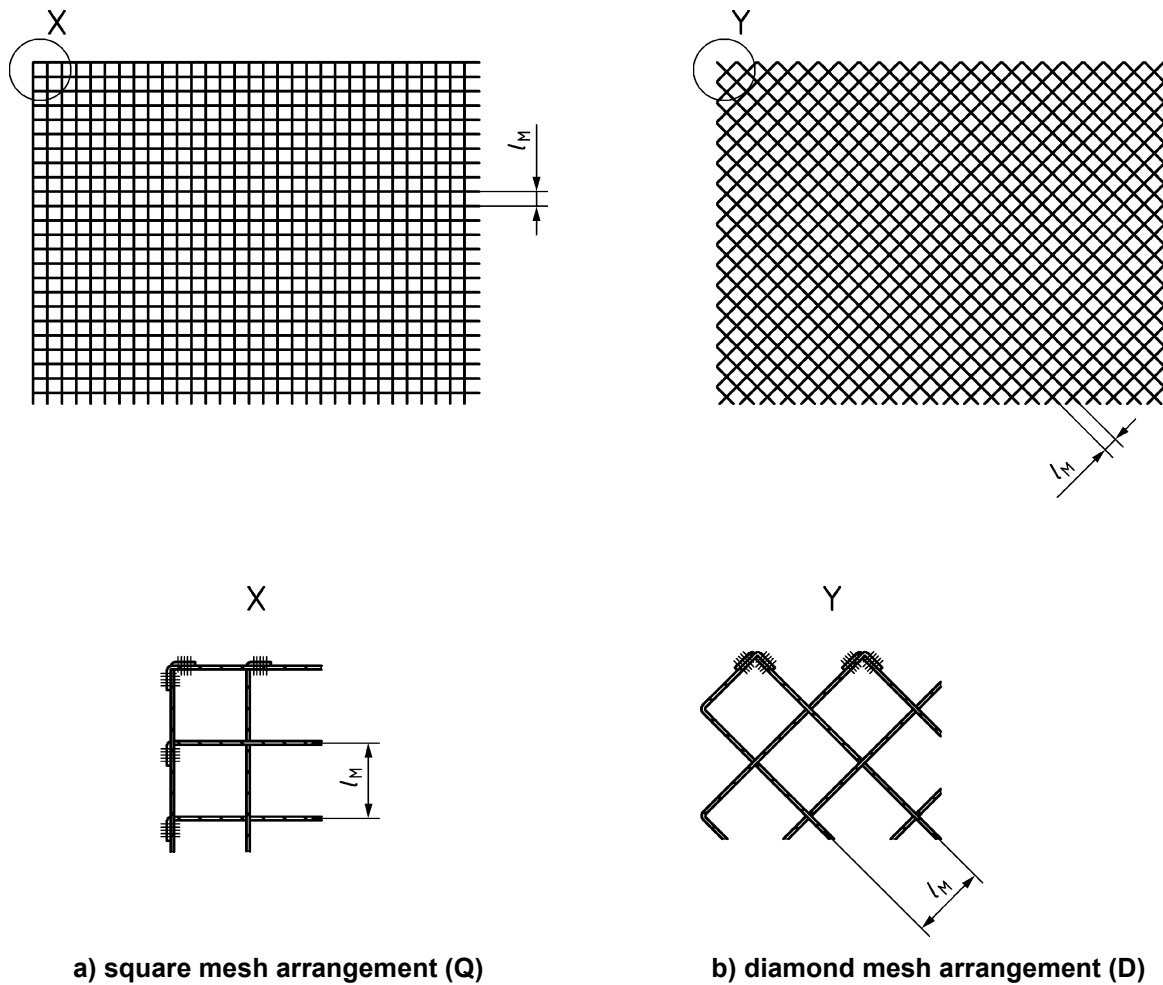

Figure 6 — Mesh size and arrangement

6.1.3 Border rope

The border rope shall pass through each mesh at the edges of the net, whether sewn or not.

The joint between the ends of a border rope shall be secured against unintentionally becoming undone. This can be achieved, e.g. by splicing. Border rope shall be tested in accordance with 7.3.

6.1.4 Other ropes

The ends of all ropes used in safety nets shall be secured against unravelling, e.g. by melting or tying or sewing with rigging yarn. The knots or connections between the ends of ropes within the selvage of a net shall be secured against unintended opening. This can be managed, e.g. by sewed overlocking of a minimum of 200 mm.

The internal length of a loop shall be at least 150 mm, see Figure 5.

6.1.5 Test mesh for yearly inspection

Safety nets shall be provided with at least one test mesh. The test mesh shall be loosely threaded through the meshes of the net and be attached in the border area. The test mesh shall come from the same production run as that used for the related net. In order to ensure that the test mesh origin can be properly identified (with the related netting), seals with the same identity number shall be fixed to the test mesh and to the related net.

EN 1263-1:2014 (E)

6.1.6 Supporting framework

When erected, the framework shall be such that the net can be supported by fixing each mesh rope directly or anchored to it along the edge at intervals not exceeding 2,5 m, using the border rope.

While the distance between the gallows (see Figure 4) shall be $\leq 5,00$ m, the border rope at the top is supported due to the construction at these distances.

6.2 Tensile strength of ropes

6.2.1 Border rope

The Rope K shall have a minimum tensile breaking force of 30,0 kN when tested according to 7.5. The joint between the ends of the Rope K shall have a minimum tensile breaking force of 24,0 kN.

The Rope P and the Rope W shall have a minimum tensile breaking force of 20,0 kN when tested according to 7.5. The joint between the ends of the Rope P and Rope W shall have a minimum tensile breaking force of 16,0 kN.

The Ropes K, P and W shall be twisted or braided.

NOTE 1 The values of the minimum tensile breaking force include a safety factor of 2,0.

NOTE 2 Twist means one thread round about another to form a cord. Braid means: Interwoven or plaited.

6.2.2 Tie rope

The rope L or M shall have a minimum tensile breaking force of 30,0 kN when tested according to 7.5. The rope R or Z shall have a minimum tensile breaking force of 15,0 kN when tested according to 7.5.

The Rope F shall have a minimum tensile breaking force of 20,0 kN when tested in accordance with 7.5.

The Ropes F, G, H, R, J, L, M and Z shall be twisted or braided.

NOTE The values of the minimum tensile breaking force include a safety factor of 2,0.

6.2.3 Coupling rope

Rope N and Rope O shall have a minimum tensile breaking force of 7,5 kN when tested according to 7.5.

The Ropes N and O shall be twisted or braided.

NOTE The value of the minimum tensile breaking force includes a safety factor of 2,0.

6.3 Energy absorption capacity of the test mesh

When testing for yearly inspection it shall be shown that the test mesh has a sufficient resistance with respect to its deterioration due to ageing over a one year period. The sufficient capacity by taking account of ageing shall be verified according to 7.7.

6.4 Static strength of a net sample

6.4.1 Breaking energy

The breaking energy E_0 in kilojoules of a net in the as new state shall be at least:

$$E_0 \geq E_N \times \gamma_1 \times \gamma_2$$

EN 1263-1:2014 (E)

where

- E_0 the breaking energy of a net in the as new state, see 7.4.3;
- E_N the action value of energy for class $N = A$ and class $N = B$, see 4.1;
- γ_1 the general safety factor; $\gamma_1 = 1,5$;
- γ_2 the specific coefficient for the deterioration due to ageing, see 7.7 resp. 7.8.

6.4.2 Displacement

When testing in accordance with 7.4, the vertical displacement of the test mass up to the point at which the net brakes shall be between 0,8 m and 1,5 m.

6.5 Dynamic strength of safety net System S (net with border rope)

System S safety nets (net with border rope) shall be tested in accordance with 7.9. The maximum instantaneous deflection of the net under dynamic action shall not exceed 75 % of the length of the shortest side of the net. The test mass shall be held by the net in each test. Permanent deformation and breaking of several mesh ropes is permitted.

6.6 Dynamic strength of safety net System T (net attached on brackets for horizontal use)

Safety nets System T shall be tested according to 7.10. The maximum instantaneous deflection of the net under dynamic action shall not exceed the length of the shortest side of the net. The test mass shall be held by the net in each test. Permanent deformation is permitted. The test mass shall not touch any element of the supporting framework.

6.7 Dynamic strength of safety net System U (net attached to supporting construction for vertical use)

System U safety nets shall be tested in accordance with 7.11. The test mass shall be held by the net in each test. Permanent deformation is permitted. The mesh ropes at the edge of the net shall not brake.

6.8 Dynamic strength of safety net System V (net with border rope attached to a gallow type support)

Safety nets System V shall be tested according to 7.12. The maximum instantaneous deflection of the net under dynamic action shall not exceed 50 % of the length of the shortest side of the net. The test mass shall be held by the net in each test. Permanent deformation is permitted.

7 Test methods

7.1 General

Unless otherwise indicated testing shall be conducted by way of visual examination, length measurement and by weighing.

Ropes need not be subjected to further testing if evidence of the tensile strength according to EN ISO 2307 has been furnished by the manufacturer by way of certificates.

Prior to the test the nets and ropes shall have been stored at an air temperature of $(20 \pm 2) ^\circ\text{C}$ and a relative humidity of $(65 \pm 5) \%$ for 72 h.

EN 1263-1:2014 (E)

7.2 Dimensional inspection of the mesh size

For the dimensional inspection of the mesh size cut at least 7 meshes in the production sequence (repeating pattern) from the net. Hang the top mesh from a fixing point with a diameter of (11 ± 1) mm. Attach a weight with a mass of $(1 + \frac{0.2}{0})$ kg to the seventh mesh. The weight should hang freely; its fixing point should be (11 ± 1) mm (see Figure 7).

The section L is measured over 5 meshes between the connecting point of the first and second mesh and the connecting point of the 6th and 7th mesh.

The measurement shall be started after a period of (60 ± 10) s has elapsed. The mesh size l_M (half mesh) is obtained by dividing L by 10.

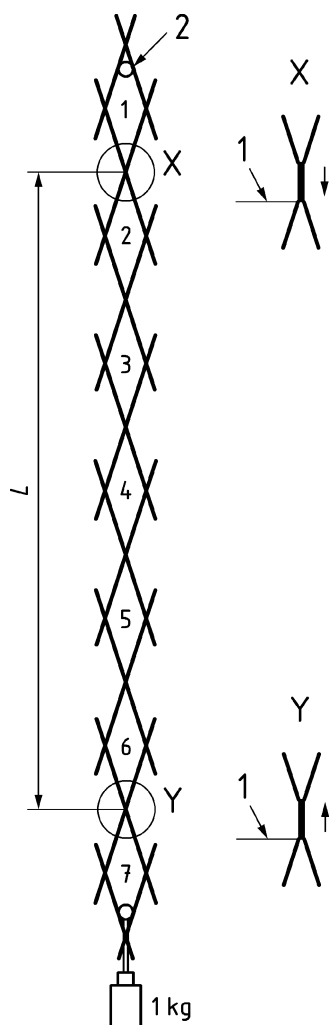

Key

- 1 measure point
- 2 fixing point at the 1st mesh

Figure 7 — Dimensional inspection

7.3 Test method for mesh rope

7.3.1 Selection of test samples

A piece of net is cut out of the net material in such a way as to produce a sample with a length of $3 l_M$. This will include the lengths of three mesh ropes and with two connection points (knots), see Figure 8.

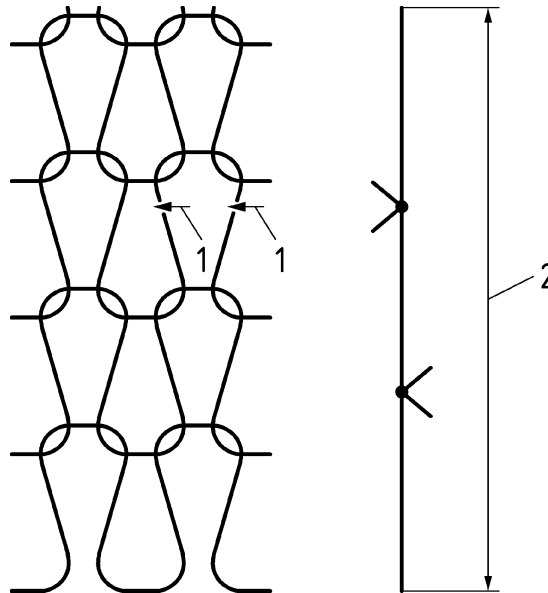

Key

- 1 cutting points of the mesh yarn
- 2 test sample includes the lengths of three mesh ropes ($3 l_M$)

Figure 8 — Test sample

7.3.2 Test apparatus

The test apparatus comprises a rigidly mounted holder with a clamp into which the upper end of the test sample can be fitted and a test mass of $(2 \pm 0,1)$ kg with a second clamp to hold the lower end of the test sample. It shall be possible to raise the test mass by at least 50 mm and then release it, see Figure 9.

EN 1263-1:2014 (E)

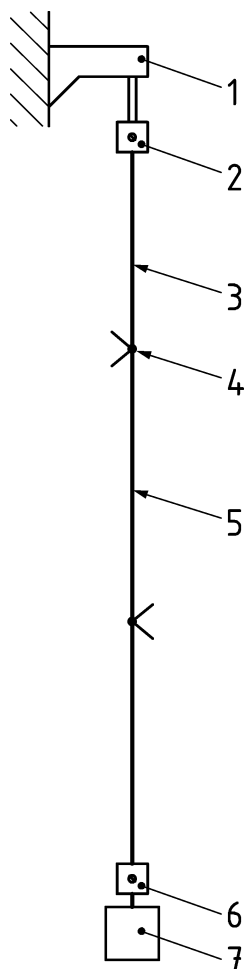

Key

- 1 rigid fastening clamp
- 2 fastening clamp to fix the upper end of the test sample
- 3 mesh rope
- 4 connection point (knot)
- 5 section in which the cutting points of the mesh bars (thread) are located
- 6 fastening clamp to fix the lower end of the test sample
- 7 test mass

Figure 9 — Test rig

7.3.3 Test method

Prior to testing, both legs of one of the outer thread systems shall be cut through between the two connection points. The upper end of the test sample is fastened onto the rigidly mounted clamp and the lower end of the test sample fixed with the clamp of the test mass at a distance of three mesh widths l_M . The test sample shall

be freely suspended. To perform the test, the test mass is raised so that it can fall freely by 50^{+5}_0 mm when released. This procedure is repeated 10 times. Observe the test sample to see if it holds the test mass and whether the cut continues to develop over the adjacent connection points.

7.4 Test for the static strength of nets

7.4.1 Selection of test samples

Three identical $(3 \pm 0,1)$ m \times $(3 \pm 0,1)$ m net samples shall be selected by random.

7.4.2 Test mass and test apparatus

The test mass shall consist of:

- a smooth-surfaced steel sphere of (500 ± 10) mm diameter and a mass of not less than 50 kg.

The test apparatus shall consist of:

- a traction device with a tractive power of at least 50 kN at a velocity of $(1 \pm 0,1)$ m/min;
- a horizontal construction at least of tube steel with a diameter of 48,3 mm and a wall thickness of 2,9 mm which is to be fixed together to form a stable frame and which is supported unflexible, e.g. on an anchored rack;
- a dynamometer with recording unit able to record an accuracy of ± 1 % of the value displayed in a range between 5 kN and 50 kN;
- a measuring instrument for displacement able to record an accuracy of ± 1 % of the value displayed in a range between 0,25 m and 2,5 m.

EN 1263-1:2014 (E)

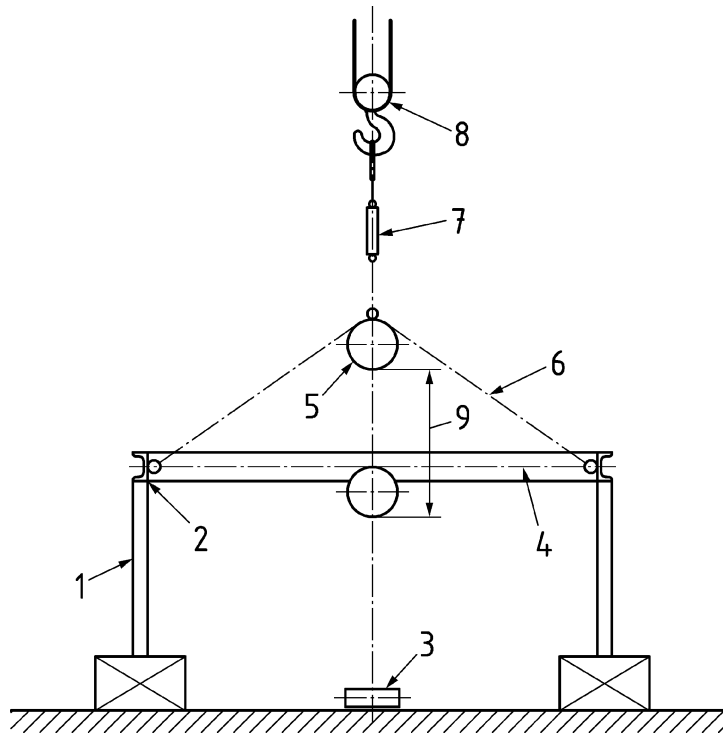

Key

- 1 rack
- 2 frame
- 3 displacement pick up
- 4 unstressed net
- 5 test mass: steel ball Ø 500 mm
- 6 net under test
- 7 dynamometer
- 8 block and tackle
- 9 displacement of the test mass

Figure 10 — Static energy absorption test for nets, (principal sketch)

7.4.3 Procedure

The datum level for determining this displacement shall be assumed to be the plane surface defined by the centre lines of the frame tubes, see Figure 10.

Prior to testing the deflection of the unloaded test sample shall be (5 ± 1) cm.

Every single border mesh of the net shall be fixed to the frame tubes with karabiners, see Figure 11.

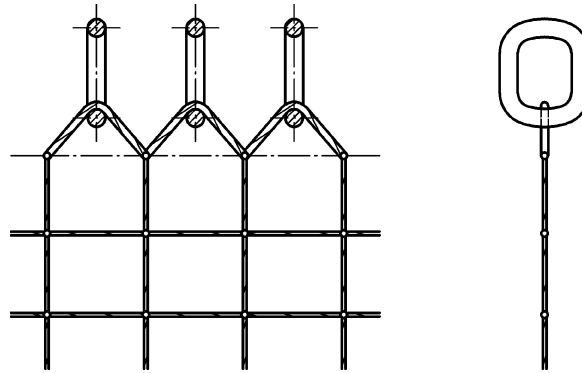

Figure 11 — Fixing the net to the frame tubes, (principal sketch)

The force shall be applied to the test mass located at the centre of the net until the net is ruptured.

The breaking energy E_0 measured by the test shall be recorded.

The displacement of the test mass representing the displacement in the net's centre shall be recorded.

7.5 Test for the breaking load of border-, tie- and coupling ropes

The breaking load of the border-, tie- or coupling ropes shall be determined in accordance with EN ISO 2307.

7.6 Test for the energy absorption capacity of the net mesh

The energy absorption capacity of the mesh shall be determined in accordance with 7.7.4 or 7.8.4.

7.7 Natural ageing test

7.7.1 General

For the determination of the specific coefficient γ_2 for the deterioration due to ageing additional to the static strength of the net in the as new state, the energy absorption capacity of the net mesh shall be determined taking into account 10 test samples in the as new state and 10 test samples after natural ageing.

The period of the natural ageing test shall be at least 12 months with the net for the mesh samples placed outdoors in a horizontal position.

In addition of calculating the deterioration of the net all due consideration should be taken of the ambient conditions (e.g. temperature, rainfall, hours of insolation) at the place of test exposure.

7.7.2 Selection of test samples

Ten samples should be taken at random from an additional net sample of a size sufficient for the traction test according to EN ISO 1806 immediately after delivery in the as new state and 10 more after exposition subjected to ageing.

7.7.3 Test apparatus

The traction test shall be carried out with a test machine tested according to EN ISO 7500-1.

The machine shall be equipped with instruments:

- to measure the elongation of the samples at the breaking point;

EN 1263-1:2014 (E)

- to measure the pertaining tension force;
- record the force-elongation.

The accuracy shall be $\pm 1\%$ of the value displayed in an area between 10 % and 100 % of the measuring range.

7.7.4 Determination of the capacity of the test mesh

7.7.4.1 Test procedure

The samples shall be attached to the machine by means of a special attachment device, e.g. as shown in EN ISO 1806. Bolts with a diameter of (20 ± 1) mm are to be used for the clamping device, any attachment device, e.g. as shown in EN ISO 1806.

The test procedure shall follow the requirements of EN ISO 1806 with the following exceptions:

The knots of the mesh of knotted nets may be fixed at the free ends to prevent the mesh ropes slipping through the knode.

The test rate for all meshes should be (200 ± 10) mm/min irrespective of the length of the test.

Prior to the test samples shall be conditioned on a climatic chamber at (20 ± 2) °C and (65 ± 5) % relative humidity in accordance with ISO 554.

7.7.4.2 Interpretation of the results

- a) The energy E_{vi} represented by the area A_{vi} resulting from the force-elongation graph up to the maximum tensile force of the sample i subjected to aging shall be calculated for each sample i ($i = 10$), see Figure 12.

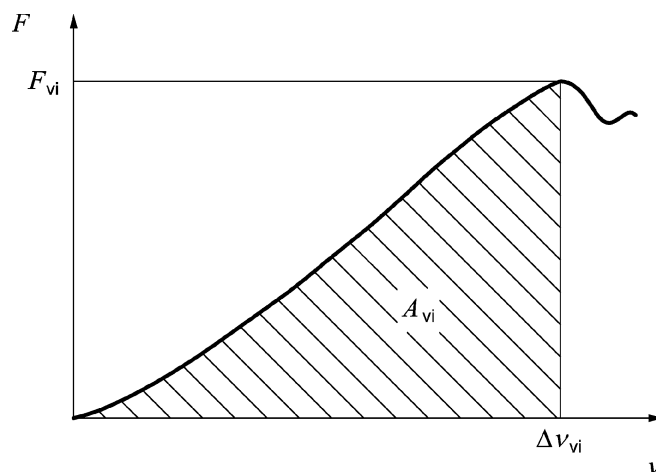

Figure 12 — Force-elongation graph of the mesh samples subjected to ageing

- b) The energy E_{0j} represented by the area A_{0j} resulting from the force-elongation graph up to the maximum tensile force of the sample j in the as new state shall be calculated for each sample j ($j = 1 \dots 10$), see Figure 13.

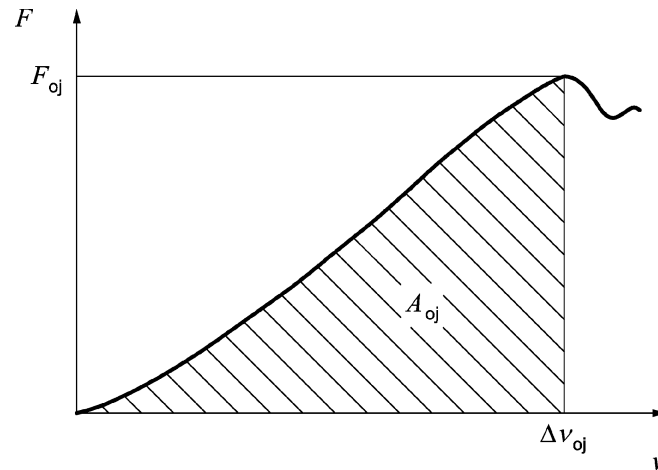

Figure 13 — Force-elongation graph of the mesh samples in the as new state

- c) Calculation of the relationship R between the sum of the amount of energy E_{vi} of 10 samples subjected to ageing and the sum of the amount of energy of three samples in the as new state:

$$R = \frac{\sum_{i=1}^{10} E_{vi}}{\sum_{j=1}^{10} E_{0j}}$$

- d) Calculation of the arithmetical mean $\langle F_0 \rangle$ of the tensile breaking force of the tensile breaking force F_{vi} of 10 samples in the as new state and $\langle F_v \rangle$ of the tensile breaking force F_{0j} of 10 samples subjected to ageing:

$$\langle F_0 \rangle = \frac{1}{10} \sum_{j=1}^{10} F_{0j}$$

$$\langle F_v \rangle = \frac{1}{10} \sum_{i=1}^{10} F_{vi}$$

where

F_{0j} is the maximum tensile force of the sample j in the as-new state, in newtons;

F_{vi} is the maximum tensile force of the sample i subjected to ageing, in newtons.

- e) With the coefficient of correlation (L_{12}) between the breaking energy of a mesh and the breaking energy of a net, each with respect to ageing,

$$L_{12} = 1 - R^{-0,31} \cdot \left[\frac{\langle F_v \rangle}{\langle F_0 \rangle} \right]^{1,31}$$

the calculated loss of breaking energy ΔE_{12} of a net under reference conditions (20 ± 2) °C, (65 ± 5) % relative humidity after ageing over a period of 12 months is calculated as follows:

EN 1263-1:2014 (E)

if $L_{12} \leq 0$, $\Delta E_{12} = 0$

if $L_{12} > 0$, $\Delta E_{12} = E_0 \cdot L_{12}$ and $E_{12} = E_0 - \Delta E_{12}$

where

E_0 breaking energy of a net in the as new state under reference conditions;

E_{12} breaking energy of a net after 12 months of ageing under reference conditions.

7.7.4.3 Calculation of the specific coefficient γ_2 for deterioration due to ageing

The specific coefficient γ_2 of the respective net for the deterioration due to ageing over a period of at least 12 months is given by the equation

$$\gamma_2 = \frac{E_0}{E_{12}}$$

7.8 Artificial ageing test

7.8.1 General

For the determination of the specific coefficient γ_2 for the deterioration due to ageing the energy absorption capacity of the net mesh shall be determined taking into account three test samples in the as new state and with three test samples after artificial ageing, if no results natural ageing are available.

7.8.2 Selection of test samples

For the selection of test samples see 7.7.2.

7.8.3 Chamber for artificial ageing

7.8.3.1 Specifications

The test chamber and the test method for the accelerated ageing test shall comply with the specifications of EN ISO 4892-1 if there are no other specifications given in the following:

a) Source of light:

Cylindrical medium or long xenon arc lamp, combined with filters, one an internal quartz filter and the other, an external borosilicate filter, allowing elimination of wavelengths less than 290 nm practically absent from the solar spectrum.

b) Test rack:

The speed of rotation of the rack shall be between 1 min^{-1} and 5 min^{-1} .

c) Watering device:

Spraying, to water the front surface of all test samples, shall comprise one or more rainwater type sprayers, angle of the jet 50° . The unit flow shall be 15 l/h to 25 l/h. The sprayers shall be mounted on the same vertical and supplied with water of resistivity equal to or greater than $10^6 \Omega \cdot \text{cm}$.

The watering system shall be constructed so as to prevent any contamination of the water sprayed. The temperature of the water shall be between 10°C and 30°C .

EN 1263-1:2014 (E)

d) Source of radiant light:

The illuminating energy of the lamp shall be inspected at the start of each period of exposure in a dry atmosphere (a maximum relative humidity of the air of 30 %) using a radiometer.

The radiometer used shall incorporate an interferential filter centred on (365 ± 2) nm; its bandwidth is indicated by the curve in Figures 14 and 15, the bandwidth being equal to (20 ± 3) nm for transmission $\tau \geq 60$ %.

To avoid any deterioration of the measuring apparatus, the inspection shall be performed at ambient temperature.

The radiometer shall be placed at the same distance from the lamp as the test samples and in its median plane.

For a given setting of the lamp power, it is necessary to provide for the angular position of the radiometer which will provide a maximum reading of the value of the energy radiated.

Since this operation is potentially damaging the health of operators, it is recommended to take the necessary precautions to avoid any hazards during handling.

With this type of apparatus, the power of the lamp should be adjusted at each inspection to obtain a mean lighting energy E_m equal to $(2,2 \pm 0,2)$ in mW/cm^2 .

In the case of use of an integrating radiometer, the inspection shall be performed when the rack is rotating at a speed of 2 min^{-1} , by measuring the quantity per unit area of radiant energy expressed in millijoules per square centimetres received by the radiometer during a whole number n of rotations, $n \geq 4$.

In other cases, the inspection shall be performed by means of eight measurements on the periphery, according to a regular pitch of $1/4$; the duration of each measurement shall be from 15 s to 20 s.

The radiometer shall be calibrated periodically, in relation to a reference standard radiometer, calibrated by an authorized body.

e) Relative humidity:

The relative humidity of the air circulating in the test chamber shall be maintained within the limit values specified for each conditioning and inspected using an appropriate instrument protected from the lamp radiation.

f) Temperatures:

The temperature (Θ_E) of the chamber around the test samples shall be measured with protection from the lamp radiation.

The temperature of the black panel thermometer (Θ), if the latter is placed near the test samples in the median plane of the lamp, shall be within the following limit values, irrespective of its position along the rack:

$$\Theta_E + 15 \leq \Theta \leq \Theta_E + 25 \text{ in degrees Celsius}$$

If a different location is chosen for the thermometer, the permissible temperature limit values shall be determined by previous calibration such that the range of temperatures indicated above is respected.

The surface condition of the black panel shall be checked once a week.

EN 1263-1:2014 (E)

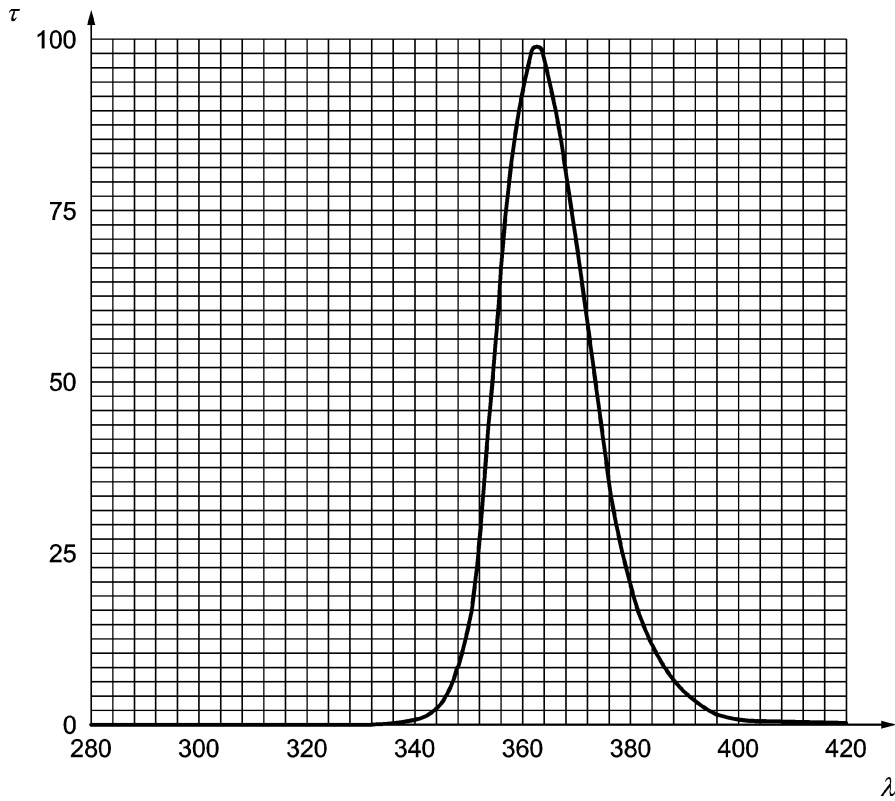

Key

- τ transmission in percent
- λ wavelength in nanometers

Figure 14 — Filtered radiometer band between 300 nm and 420 nm

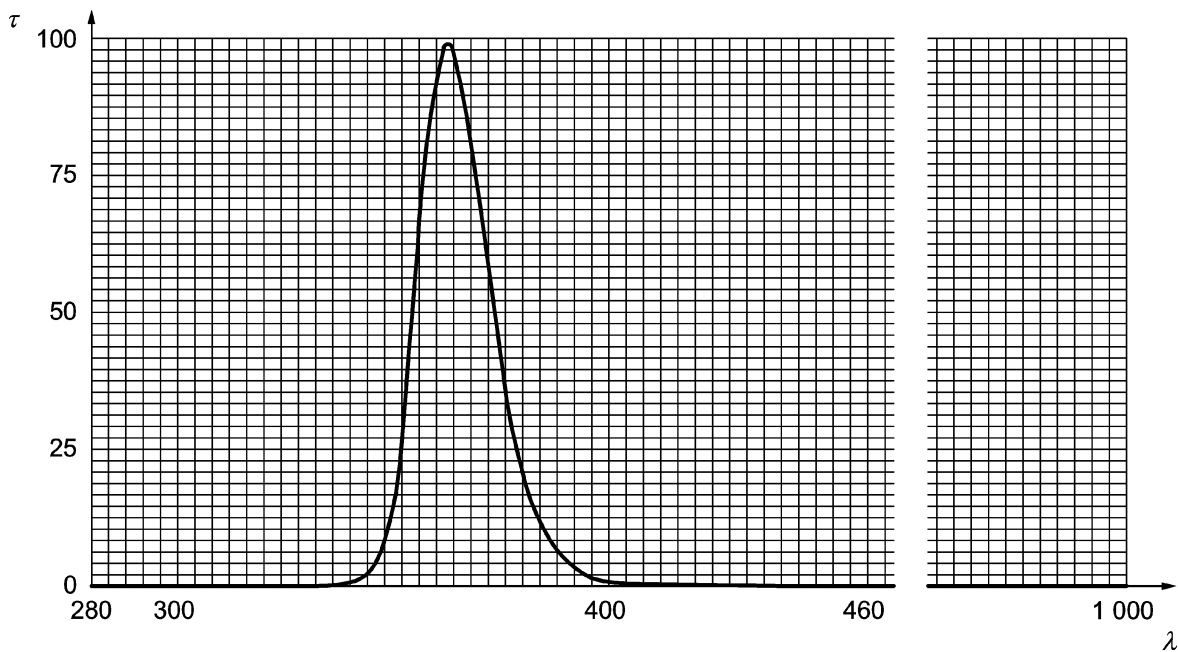

Key

- τ transmission in percent
- λ wavelength in nanometers

Figure 15 — Filtered radiometer band between 280 nm and 1000 nm

EN 1263-1:2014 (E)

In the case of contradicting specifications, 7.8.3 shall prevail over EN ISO 4892-1.

7.8.3.2 Positioning of samples

The three samples shall be mounted to the test rack according to Figure 16.

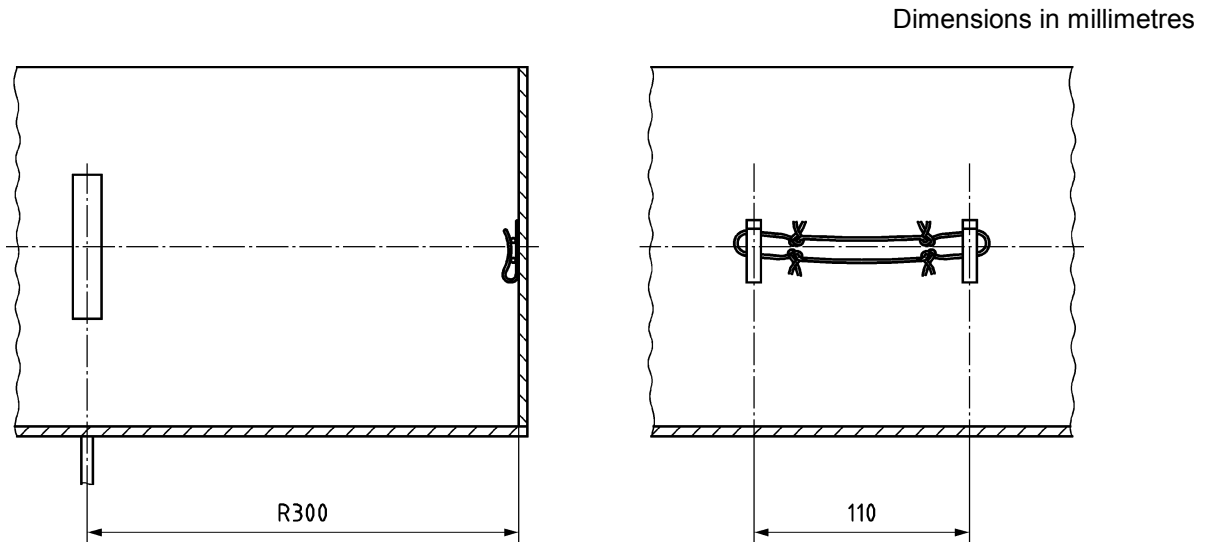

Figure 16 — Positioning of the samples in the ageing chamber

7.8.3.3 Ageing cycle

The samples shall be exposed to the ageing cycle for 336 times (see Figure 17), the cycle being:

- 20 min of spraying with distilled water at (20 ± 2) °C;
- 10 min of increasing the ambient temperature to 80 °C;
- 100 min of drying at a temperature of (80 ± 2) °C and (15 ± 5) % relative humidity;
- 10 min of decreasing the temperature to 60 °C;
- 90 min of exposure to UV-radiation at a temperature of 60 °C, measured with a thermometer with a black background, with the ambient temperature being (36 ± 2) °C and the relative humidity being (20 ± 5) %;
- 10 min of decreasing the temperature to 20 °C.

The maximum duration of the test including periods of disuse shall be 70 d, representing a natural ageing period of 6 months. The test period shall be extended, if a natural ageing of 12 months is requested.

EN 1263-1:2014 (E)

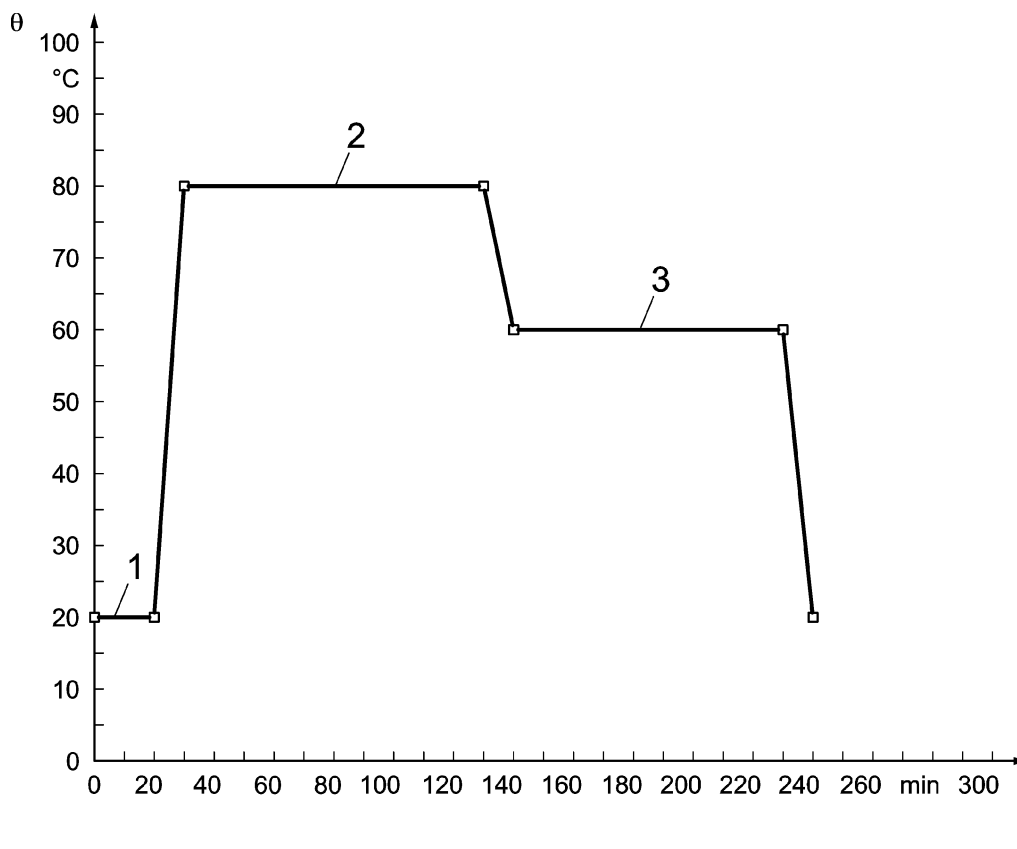

- Key**
- 1 rain
 - 2 drying
 - 3 UV-radiation
 - t time in minutes
 - θ temperature in degrees Celsius

Figure 17 — Accelerated ageing cycle

7.8.4 Determination of the capacity of the net mesh

7.8.4.1 Test procedure

For the test procedure, see 7.7.4.1.

7.8.4.2 Interpretation of the results

For the interpretation of the results after artificial ageing, see 7.7.4.2, except:

- e) The coefficient of correlation between the breaking energy of a mesh and the breaking energy of a net, each with respect to ageing,

$$L_6 = 1 - R^{-0,31} \cdot \left[\frac{\langle F_v \rangle}{\langle F_o \rangle} \right]^{1,31}$$

The calculated loss of breaking energy ΔE_6 of a net under reference conditions (20 ± 2) °C, (65 ± 5) % relative humidity after ageing over a period of 6 months is calculated as follows:

EN 1263-1:2014 (E)

if $L_6 \leq 0$, $\Delta E_6 = 0$

if $L_6 > 0$, $\Delta E_6 = E_0 \cdot L_6$ and $E_6 = E_0 - \Delta E_6$

where

E_0 is the breaking energy of a net in a new state under reference conditions;

E_6 is the breaking energy of a net after 6 months of ageing under reference conditions.

7.8.4.3 Calculation of the specific coefficient γ_2 for deterioration due to ageing

The calculated loss of energy ΔE_{12} of a net after ageing over a period of at least 12 months is given by the relation

$$\Delta E_6 = E_0 - E_6$$

$$\Delta E_{12} = 2 \Delta E_6 \text{ and } E_{12} = E_0 - \Delta E_{12}$$

where

E_0 breaking energy of a net in a new state under reference conditions;

E_{12} breaking energy of a net after 12 months of ageing under reference conditions.

The specific coefficient γ_2 of the respective net for the deterioration due to ageing over a period of at least 12 months is given by the formula:

$$\gamma_2 = \frac{E_0}{E_{12}}$$

7.9 Testing the dynamic strength of safety nets System S (net with border ropes)

7.9.1 Selection of test samples

For testing the dynamic strength a net sample of System S safety nets of $(5 \pm 0,1) \text{ m} \times (7 \pm 0,1) \text{ m}$ length of sides (measured from edge to edge) shall be used.

7.9.2 Test mass

The test mass shall be the steel sphere as described in 7.4.2, but deviating concerning the mass which shall be $(100 \pm 1) \text{ kg}$.

7.9.3 Test Procedure

The test sample shall be rigidly suspended by its four corners via the border rope (see Figure 18). The fixing point shall have a diameter of $(11 \pm 1) \text{ mm}$. Before the test is started a 500 N pretensioning force shall be applied with an accuracy of $\pm 10 \%$ at each anchorage point. The initial sag shall be measured.

The test mass shall be dropped twice into the centre of the test sample. The drop height shall be adjusted, such that energy of the test mass is 7 kJ with an accuracy of $\pm 1 \%$.

The second test shall be carried out within $(30 \pm 15) \text{ min}$ after the first test.

After each test the maximum displacement shall be recorded and compared with the value specified in 6.5.

EN 1263-1:2014 (E)

Dimensions in centimetres

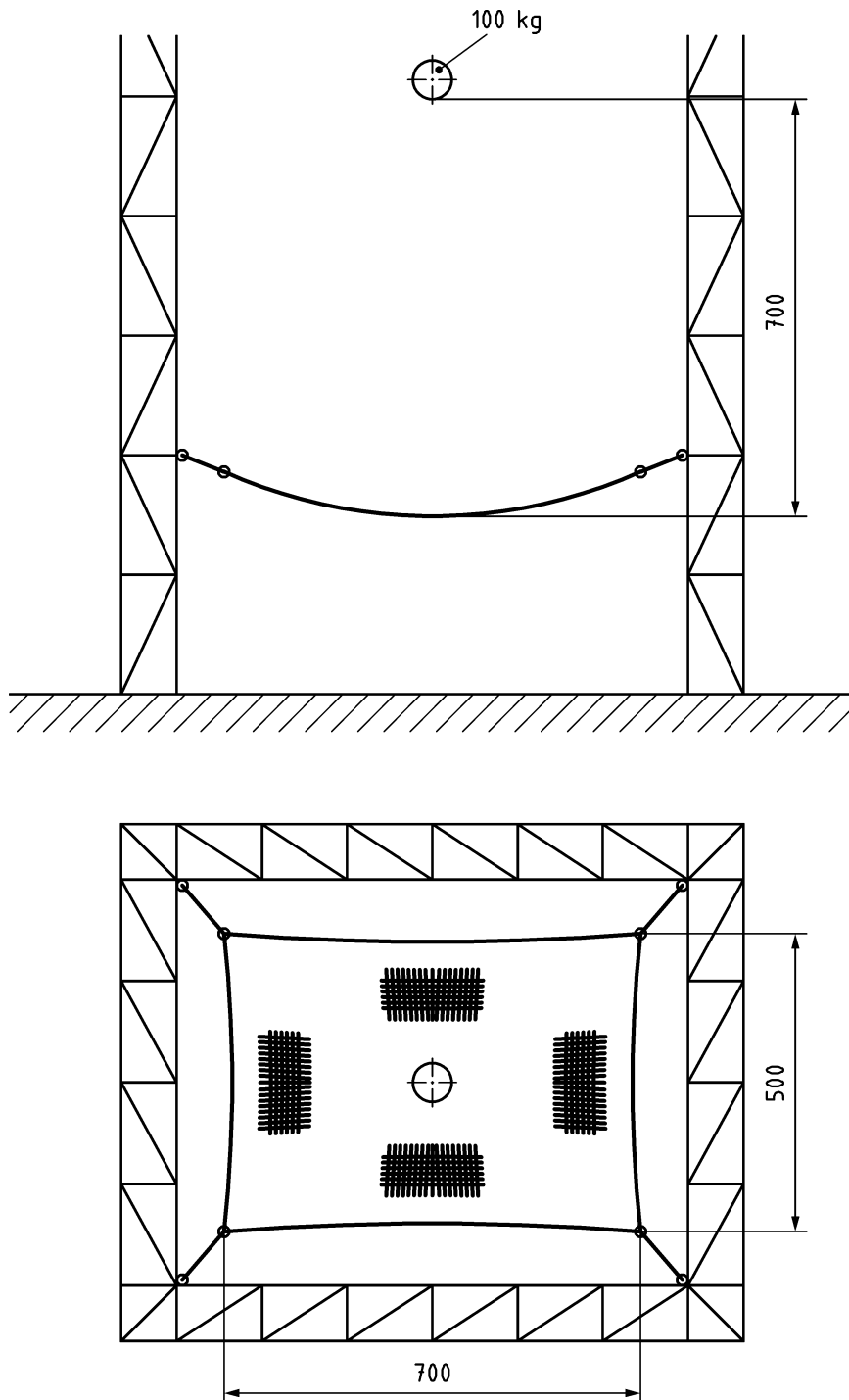

Figure 18 — Dynamic test method for safety net system S

7.10 Testing the dynamic strength of safety nets System T (nets attached on brackets for horizontal use)

7.10.1 Selection of test samples

One sample of the net over two bays and three samples of the brackets each from the original system shall be used for each test while two tests are recommended see 7.10.3.

7.10.2 Test mass

The test mass shall be the steel sphere as described in 7.9.2.

7.10.3 Test Procedure

The test sample shall be installed according to the manufacturer's instructions.

The test mass shall be dropped twice into the centre of the net between two brackets. The drop height shall be adjusted such that energy of the test mass is 7 kJ with an accuracy of $\pm 1\%$, (see Figure 19 position a)).

The test shall be repeated twice with another sample in those areas of the net hanging above elements of the supporting framework, (see Figure 19 position b)).

No parts whether damaged or not shall be replaced between the first and the second drop of these tests.

During the testing, the instantaneous deflection of the net shall be recorded and compared with the value specified in 6.6. In addition, the net shall be checked in Figure 19 position b) to ensure that no parts of the net come into contact with the supporting framework during or after the test.

EN 1263-1:2014 (E)

Dimensions in centimetres

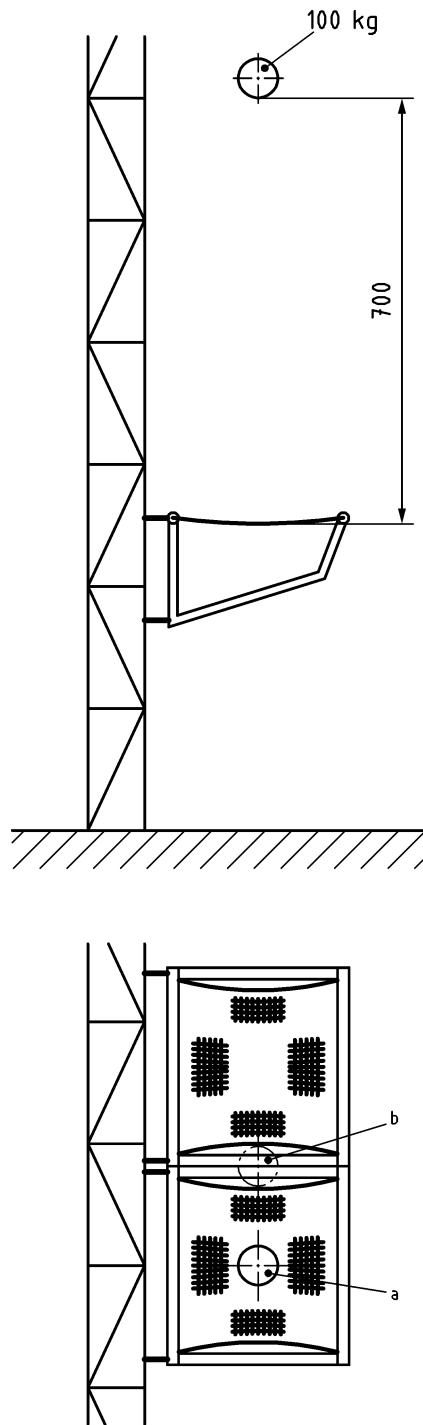

Figure 19 — Dynamic test method for safety net System T

7.11 Testing the dynamic strength of safety nets System U (net attached to supporting framework for vertical use)

7.11.1 Selection of test samples

One test sample with the dimensions (1,0 x 2,0) m including the means of fastening the frame shall be used for each test (see Figure 20). The joint between the ends of the overlock shall be secured against unintentionally becoming undone. This can be achieved e.g. by overlapping of a minimum of 20 cm.

7.11.2 Test mass and test apparatus

The test mass shall be a cylindrical body with a mass of (75 ± 1) kg, a length of $(1\ 000 \pm 10)$ mm and a diameter of (300 ± 5) mm. The cylindrical body shall be made of at least 25 mm rubber with a smooth surface without sharp edges.

The test ramp shall be plain and it shall be inclined by $(60 \pm 3)^\circ$ to the horizontal. The inclined test ramp shall have a length of at least 5,0 m. See Figure 20 for the position of the test ramp.

Dimensions in centimetres

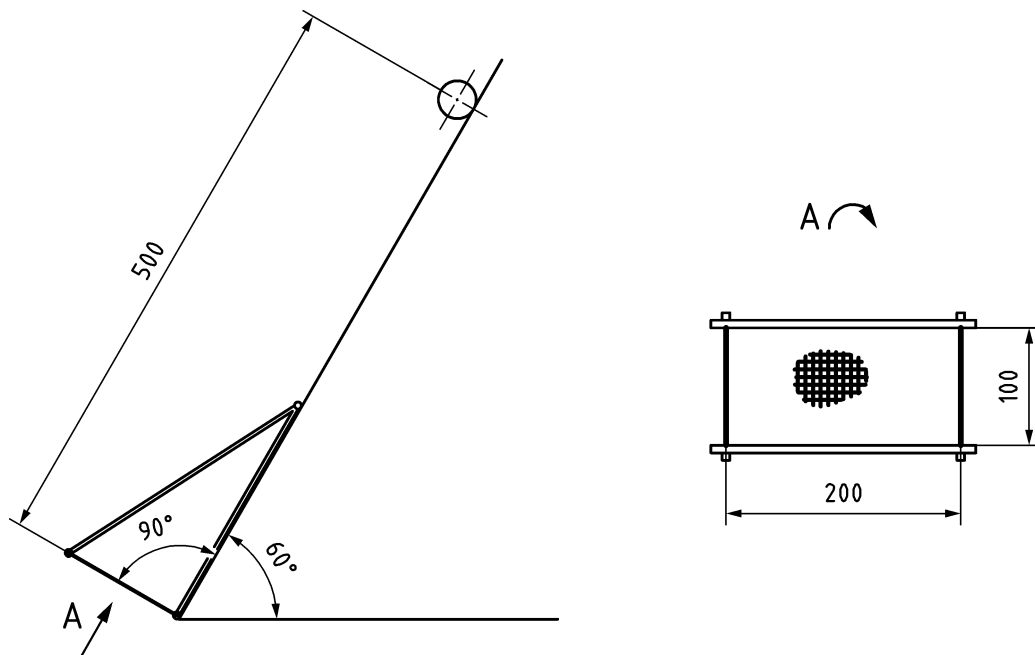

Figure 20 — Inclined test ramp for safety net System U

7.11.3 Test Procedure

The test sample shall be installed according to the manufacturer's instructions. For each sample to be tested two rolling motion tests shall be made into the centre of the net. No parts whether damaged or not shall be replaced between the first and the second test.

Check whether the test mass is held by the safety net System U after the test.

EN 1263-1:2014 (E)

7.12 Testing the dynamic strength of safety nets System V (net with border rope attached to a gallow type support)

7.12.1 Selection of test samples

When testing a $(5 \pm 0,1) \text{ m} \times (7 \pm 0,1) \text{ m}$ length of sides (measured from edge to edge) net sample of System V safety nets with the system's original dimensions and two gallow type supports shall be used for testing the dynamic strength.

7.12.2 Test mass

The test mass shall be the steel sphere as described in 7.9.2.

7.12.3 Test Procedure

The net shall be attached to the gallow type supports (see Figure 21) which same as the lower border rope shall in turn be attached to the testing supports according to manufacturer's instructions.

The distance between the supporting structures shall be $(5 \pm 0,1) \text{ m}$.

Each gallow type support shall be attached to the structure in accordance with the instruction of the manufacturer.

The lower border rope of the net shall be fastened using spiral hooks ("pigs tails") placed every $(0,5 \pm 0,02) \text{ m}$.

The test rig shall simulate the fixing of hooks into a concrete slab. The net may not pass over an edge in any test.

The sag, E , of the outer border ropes (see Figure 21) due to self-weight shall be $(0,3 \pm 0,05) \text{ m}$.

The test mass shall be dropped twice into the centre between the two gallow type supports at a horizontal distance from the attachment points of the lower border rope of the net of 50 % of the projection of the gallow type supports, this distance always being at least 1,0 m.

The drop height shall be adjusted such that energy of the test mass is 7 kJ with an accuracy of $\pm 1 \%$.

No parts whether damaged or not shall be replaced between the tests.

Following each test the instantaneous deflection of the net shall be recorded and compared with the value specified in 6.8. In addition, it shall be recorded if any parts of the net came into contact with the supporting construction during or after the test.

EN 1263-1:2014 (E)

Dimensions in centimetres

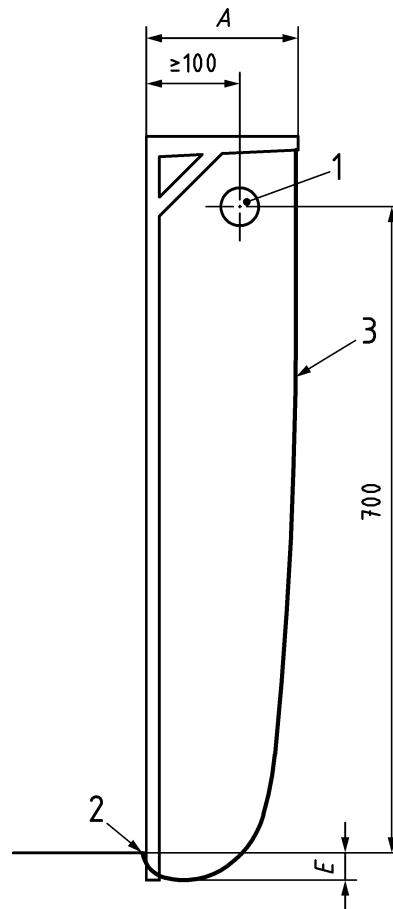

Key

- 1 test mass = 100 kg
- 2 attachment points of the gallow
- 3 border rope
- A length of the gallow
- E sag of the border ropes

Figure 21 — Dynamic test method for safety net System V (Examples only)

7.13 Test report

The test report shall refer to this standard and contain the following:

- a) a description of the test samples;
- b) the test results;
- c) a confirmation that the net complies with all the requirements of this standard.

EN 1263-1:2014 (E)

8 Marking and labelling

Safety nets shall be marked with:

- the name or mark of the manufacturer or importer;
- the designation in accordance with 5.1;
- the identity number in accordance with 6.1.5;
- the year and month of manufacture of the net;
- the minimum energy absorption capacity and minimum breaking force of the test mesh;
- the manufacturer's article code;
- sign of the competent, independent organization (for inspection level M only), if Annex B is applied.

The marking shall be permanent.

NOTE Examples of what constitutes permanent marking are labels or plastic discs sewn or riveted onto the net so that they cannot be removed without damaging it.

9 Handling instructions

Handling instructions shall be supplied with the safety net including information on:

- a) installation, use and dismantling;
- b) storage, care and inspection;
- c) dates for the test of the test meshes;
- d) conditions for withdrawal from service;
- e) any hazards warning (e.g. extreme temperature, chemical influences);
- f) declaration as given in Clause 10.

The handling instructions shall state that a safety net which had prevented a fall of a person or an object may only be used again after having been inspected by a competent person. The items (intents) listed in EN 1263-2:2014, 4.1, shall be considered.

10 Conformity

The determined requirements for the product (the nets) in accordance with this European Standard shall be declared.

This declaration may be supported by a declaration of the competent, independent organization mentioned in Annexes A and B, if Annexes A and B are agreed on.

Annex A (informative)

Prototype assessment

For prototype approval the manufacturer should ensure that the assessment of the prototype is carried out by an accredited organization.

This organization should

- check whether the performance requirements of this European Standard are fulfilled;
- carry out an independent check of all calculations;
- supervise all tests;
- check whether the dimensions of the assessed safety nets conform to the manufacturer's data.

The certificate of the independent organization shall quote the reference number of the test report or of the documentation and shall identify the equipment examined and relate the parts to the classification of Clause 5.

The certificate shall certify that the assessed safety nets have been examined in accordance with the appropriate clauses of EN 1263-1 and that it complies with this European Standard.

EN 1263-1:2014 (E)

Annex B (informative)

On-going production inspection

B.1 On-going production inspection

The manufacture of safety nets should be controlled by one of the following inspection methods:

— Inspection level L;

The production quality control will be carried out by a manufacturer approved according to EN ISO 9000 series by a notified organization.

— Inspection level M;

— The manufacturer shall maintain an appropriate quality management system (e.g. according to EN ISO 9000).

The production quality control will be carried out by a notified organization.

Minimum on-going quality control requirements are given in Table B.1.

EN 1263-1:2014 (E)

Table B.1 — Inspection of safety nets

Parameter	Property to be checked	Frequency of inspection	
		by the manufacturer	by a notified organization
Net	mesh size 4.1	measurement per delivery or charge	at least 1 measurement inspection within 5 years
	arrangement of meshes 6.1.2	visual inspection per product	at least 1 visual inspection within 5 years
	security of the edges of meshes 6.1.2		
	breaking energy 6.4.1	submission of the test report in accordance with EN 10204:2004, 2.2 per delivery or charge	at least 1 test within 5 years
Border rope	tensile breaking force 6.2.1	submission of the test report in accordance with EN 10204:2004, 2.2 per delivery or charge	at least 1 test within 5 years
	tensile breaking force of the joint 6.2.1		
	security of joint 6.1.3	visual inspection per product	at least 1 visual inspection within 5 years
Safety net	Arrangement of border rope for system S and V 6.1.3	visual inspection per product	at least 1 visual inspection within 5 years
	Dynamic strength of system S, T, U, V 6.5; 6.6; 6.7; 6.8	submission of the test report in accordance with EN 10204:2004, 2.2 per delivery or charge	at least 1 test within 5 years
Supporting framework	Unintentional movement 6.1.6	visual inspection per product	at least 1 visual inspection within 5 years
	Fixing of the net 6.1.6		
Test mesh	Available 6.1.5	visual inspection per product	at least 1 visual inspection within 5 years
Marking and labelling	available and durable Clause 8	visual inspection per product	at least 1 visual inspection within 5 years

B.2 Annual inspection of test mesh

During the annual inspection of the test mesh at least one mesh shall be tested in accordance with 7.7.4. The energy absorption capacity or its mean value shall be equal to or greater than the value stated in the marking. This ensures that the safety net has sufficient energy absorption capacity reserves to enable it to be used for a further period of one year.

NOTE If the test mesh fails within 5 % of the manufacturer's minimum energy absorption capacity of the test mesh, a second test is permitted.

EN 1263-1:2014 (E)

Bibliography

EN 10204:2004, *Metallic products — Types of inspection documents*

EN ISO 9001, *Quality management systems — Requirements (ISO 9001)*

EN ISO/IEC 17025, *General requirements for the competence of testing and calibration laboratories (ISO/IEC 17025)*